

Siltbuster®

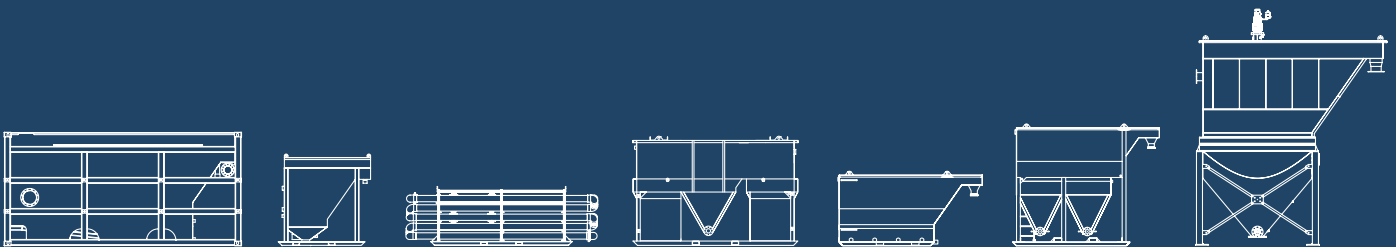

Solutions for the Concrete Industry



Hire, Sales & Technical Support



Who are Siltbuster?

At Siltbuster we pride ourselves on not being just a plant hire company but a solutions provider. Our reputation has grown over the past 10 years based on customer focused product development and ongoing technical support.

Water treatment isn't always as simple as it should be, that's why as part of our services we offer:

- Site visits to scope best solutions
- In-house laboratory testing of samples
- On-site commissioning and installation
- Telephone and on-site technical support
- Regional employees ensuring a timely response to enquiries

We have the largest hire fleet of water treatment equipment in the UK operating both nationwide and internationally, enabling us to mobilise the equipment you need for when you need it.

Our equipment is used on projects ranging from small residential developments to some of the largest civil infrastructure schemes recently undertaken including: Heathrow T5, CrossRail, Hinkley Point C, the Forth Road Bridge, Copenhagen Metro and even the odd special project such as mud runs and the raising of the Costa Concordia!

But don't just take our word for it, pages 24 - 27 show a number of example case studies of recent projects we have been involved within the concreting and hydrodemolition industries.

Why Treat Concrete Waste Water?

What is the problem?

Water that comes into contact with freshly exposed or poured concrete takes on an alkaline pH (circa 13) due to chemical reactions between the water and free lime particles within the cement.

While everyone is familiar with the dangers associated with acids, highly alkaline substances such as concrete wash water can be just as corrosive and if left unchecked/untreated can cause concrete burns, damage to vegetation and the surrounding ecosystem and ultimately result in the death of aquatic life. If it was bottled, it would require warning labels including:



Water with a high pH can look "clean", however once the solids have been removed, it still remains highly alkaline, hence the term "Silent Polluter".

Did you know...

To dilute just one IBC of concrete wash water (pH 12) you would need **four Olympic swimming pools** of water to bring it back to neutral (pH 7)! That is over 10,000 m³ of water

pH Scale



A common misconception when dealing with pH waste water is that it can be easily resolved by dilution. However, the pH scale is logarithmic therefore one unit change on the scale is a tenfold increase in strength.

Dilution to Reduce pH	
pH 11.7	1:1
pH 10	10:1
pH 9	100:1
pH 8	1,000:1
pH 7	10,000:1

Common Sources of Alkaline Waters on Construction Sites:

- Washing down of machinery used with fresh concrete, e.g. concrete chutes, drums & pumps
- Cutting or coring of concrete structures
- Hydrodemolition (high pressure water cutting)
- Surface water run-off from recently lime stabilised sites
- Stockpiled or spread crushed demolition materials
- Placement of fresh concrete beneath groundwater e.g. piled foundations
- Placement of fresh concrete in a water course e.g. Bridge abutments

Legal and Financial Implications

Environmental Implications:

Due to the minimal effect of dilution even small volumes of concrete wash water have the potential to have a significant impact when discharged into the environment potentially causing:

- Destruction of vegetation and ecosystems
- Death of aquatic life either by sudden pH changes causing "shocks" or extreme pH levels
- Damage to outer surfaces of aquatic life like gills, eyes and skin
- Inability to dispose of metabolic waste
- An increase in toxicity of other substances



Legislative:

Under the Environmental Permitting (England and Wales) Regulations 2010 (as amended in 2012) and the Water Resources Act 1991 (as amended), it is an offence to discharge polluting substances to controlled waters (surface water and groundwater) without prior approval from the Regulators (Environment Agency (EA) England or National Resources Wales (NRW)).

Therefore, measures to control, store and treat concrete wash water prior to discharge will need to be implemented. Failure to implement control measures may cause a significant pollutant to be released into the environment, having the potential to pollute both land and the aquatic environment.

It is therefore necessary to develop control over the washing down of any plant or equipment that has come into contact with fresh concrete.

Financial

The financial implications of causing a pollution incident can be crippling for an organisation. It is now common for companies to be asked to declare historical environmental incidents when tendering for work. Therefore, previous mistakes can hinder winning new projects!

Additionally, since the publication of the Sentencing Guidelines in 2014 by the Sentencing Council, firms convicted of knowingly causing a pollution incident could face fines of upto £3m!

At what pH can wash water typically be discharged?

Typical discharge consents for controlled waters ie. surface water courses and groundwater, requires a pH of between 6 & 9 (subject to Environmental Permit Limits where relevant).

Whereas, discharging to sewer typically requires a pH of between 5 & 10 (subject to agreement with the water authority, typically in the form of a Trade Effluent Consent).

Alternatively high pH water can be tankered off-site however this is an expensive option at circa £140/m³.



Purpose designed and built pH Controller by Siltbuster for accurate control, recording and neutralising of high pH water

pH Adjustment Methods

How can the pH be adjusted?

Alkaline water is traditionally neutralised by adding controlled amounts of an acid to reduce the pH.

The most commonly used reagents to neutralise alkaline waters are:

- Mineral Acid (either sulphuric or hydrochloric acid)
- Citric acid
- Carbon dioxide
- Self buffering solutions

Comparison of pH adjustment methods:

Mineral & Citric Acid

- Very hard to control (see steep titration curves below - no effect then sudden change)
- Careful chemical handling methods are needed
- If used in powdered form dose rates are easily misjudged due to time taken to fully dissolve

Carbon Dioxide

- High level of control - as it forms a very weak acid
- Slower reaction rates suited to automatic pH adjustment systems

Self buffering solutions

- Needs monitoring to ensure it is replaced once depleted

The benefits of Carbon Dioxide for pH adjustment:

Siltbuster treatment systems utilise CO₂ as an innovative way of treating high pH wash water, providing significant advantages over traditional methods.

- Carbon Dioxide is **virtually impossible to acidify the water through overdosing**
- Carbon Dioxide is more cost effective than any other solution, including mineral acid or citric acid (**£0.30 per m³ vs over £2.40 per m³**)
- Neutralisation can be accurately controlled due to the **near linear rate of neutralisation**
- Carbon Dioxide **does not elevate BOD, Chlorides, Sulphates**, etc, which would otherwise be secondary pollutants
- **Easy and safe to store** - no specialist training or PPE
- Carbon Dioxide **does not leave the site with an IBC of liquid waste or containers requiring disposal**

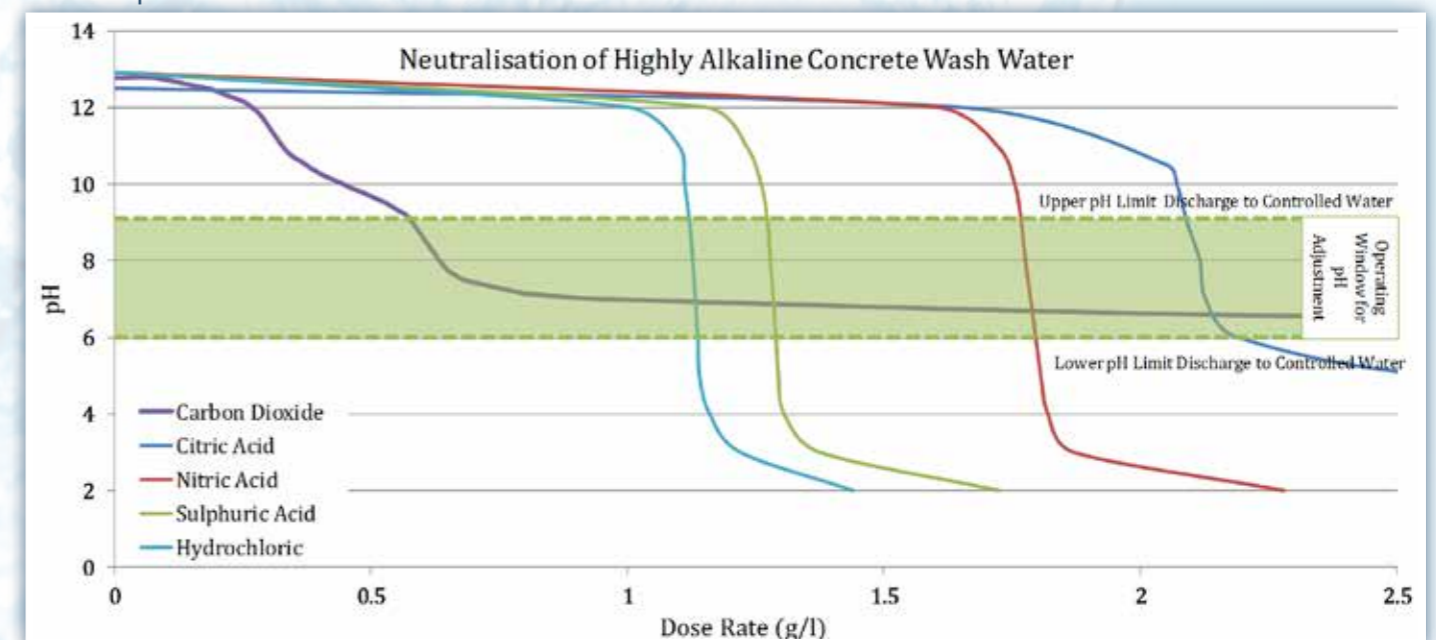

Siltbuster MCW

Compact Wash Water Recycling System



The Unit

The Micro Concrete Washout System (MCW) by Siltbuster has been developed responding to calls from the industry for a more compact and versatile system that neutralises and recycles concrete wash water.

Designed to capture and treat the water from the washing down of chutes on mixer trucks and the cleaning of small tools and plant equipment on site (such as wheelbarrows, buckets and trowels).

The system removes solids from the water, neutralises the pH and stores the grey water ready for reuse at the next wash down.

The MCW is available for immediate hire from our fleet or to purchase in our your own livery.

Did you know...

The MCW has been designed to allow it to be shipped via conventional Pallet Networks.

This enables us to typically offer Next Day Delivery for under £200.

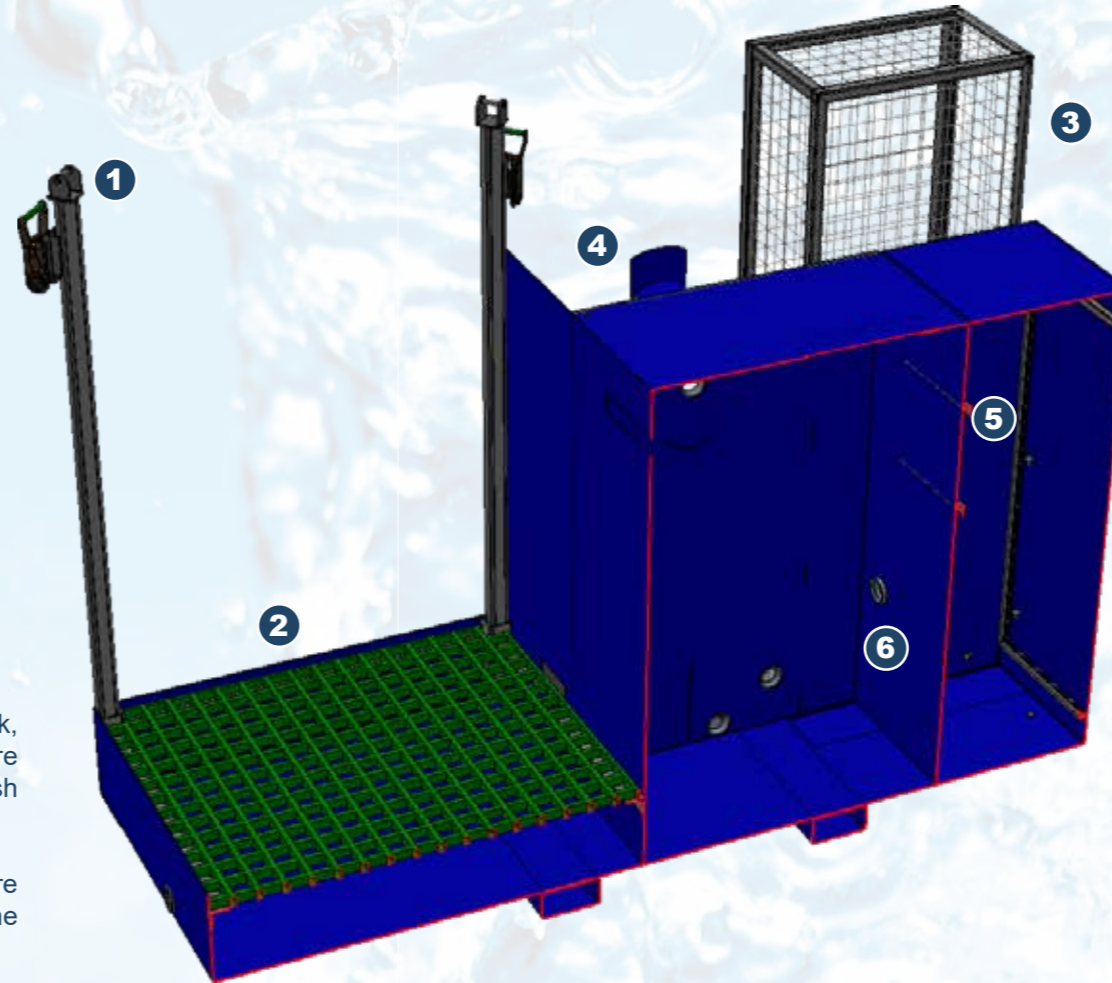

KEY ADVANTAGES

- + Compact footprint, suited to building sites or highway works
- + Built in wash down pump enables treated water to be recycled for further wash downs
- + Automatic pH adjustment system requiring minimal operator input or training

TYPICAL APPLICATIONS

- + Washing down of concrete mixer truck chutes & concrete pumps
- + Washing of hand tools, site mixers and mortar tubs
- + House builders, infrastructure projects & general construction projects

How it Works

1. Using the built-in high-pressure hose, fed from the integrated grey water storage tank, chutes are washed into the geotextile bag at the front of the unit, where the solids are retained, whilst a low level tray below retains the fine material. If tools are being wash down, these are washed directly into the tray.
2. The highly alkaline supernatant water is transferred into the grey water holding tank, where the pH is automatically neutralised using our CO₂ saturation system. (By using CO₂ as the neutralising agent, the system is fail safe, making it impossible to over adjust the pH.)
3. The neutralisation process extremely quick enabling safe reuse of the water by the time another truck has backed up to the system.

- 1** BAG SUPPORTS FOR CHUTE WASH DOWN
- 2** RECEPTION TRAY FOR PLANT WASHING
- 3** INTEGRATED GAS STORAGE CAGE
- 4** BUILT IN WASH DOWN PUMP AND HOSE
- 5** AUTOMATIC CO₂ pH ADJUSTMENT
- 6** GREY WATER HOLDING TANK

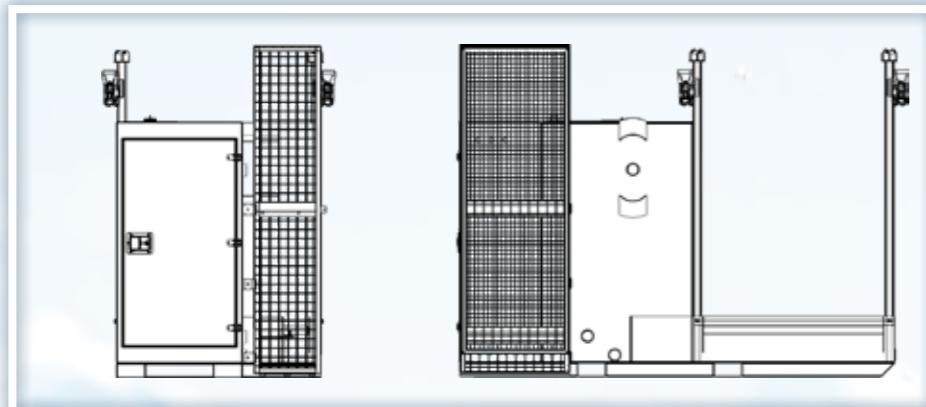

MCW Data Sheet	
Length:	2.4 m
Width:	1.2 m
Height:	1.8 m
Empty Weight:	650 kg
Capacity:	800L Water
Built Jet Wash:	optional
Power Req:	110V

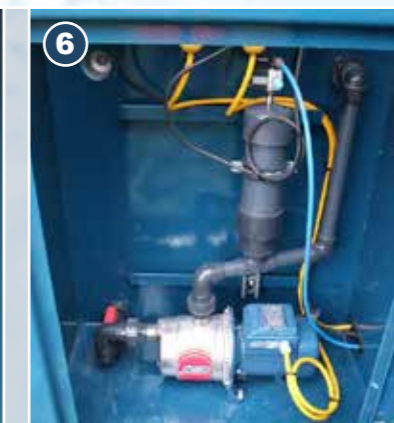

For Hire, Sales & Technical Support call Siltbuster® on 01600 772256

RCW

Concrete Mixer Chute Wash Water Treatment



The Unit

Designed specifically for treating wash water and solids generated from washing mixer truck chutes. Siltbuster's RCW (Roadside Concrete Washout) Unit provides a compact, rapidly deployable method of dealing with concrete wash water.

Recognised and adopted by many contractors as best practice, a single RCW can handle up to 30 washouts spread over a working day ensuring your site remains compliant with the Environment Agency Regulatory Position Statement (guidelines).

The RCW can either run via 110V mains supply or off an integrated 12V battery, allowing operation in the most remote locations!

How it Works

- High pH (12-13) wash water is discharged from the concrete mixer trucks chutes being washed directly into the reception hoppers
- The aggregate and cement fines are retained in the geotextile dewatering bags and allowed to hydrate whilst the water bleeds into the main storage chamber
- A battery powered, automated digital pH controller monitors the pH and automatically doses Carbon Dioxide (CO₂) to reduce the pH when an alkaline value is detected
- Once the precipitated fines are left to settle, the treated water with a pH of between 6 - 9 is manually discharged via a control valve for safe disposal or reuse on site

Did you know...
The pH scale is Logarithmic?
That is why if you were to try and dilute 1L of pH 12 wash water to return it to pH 7, it would take 100,000L of tap water to dilute it!

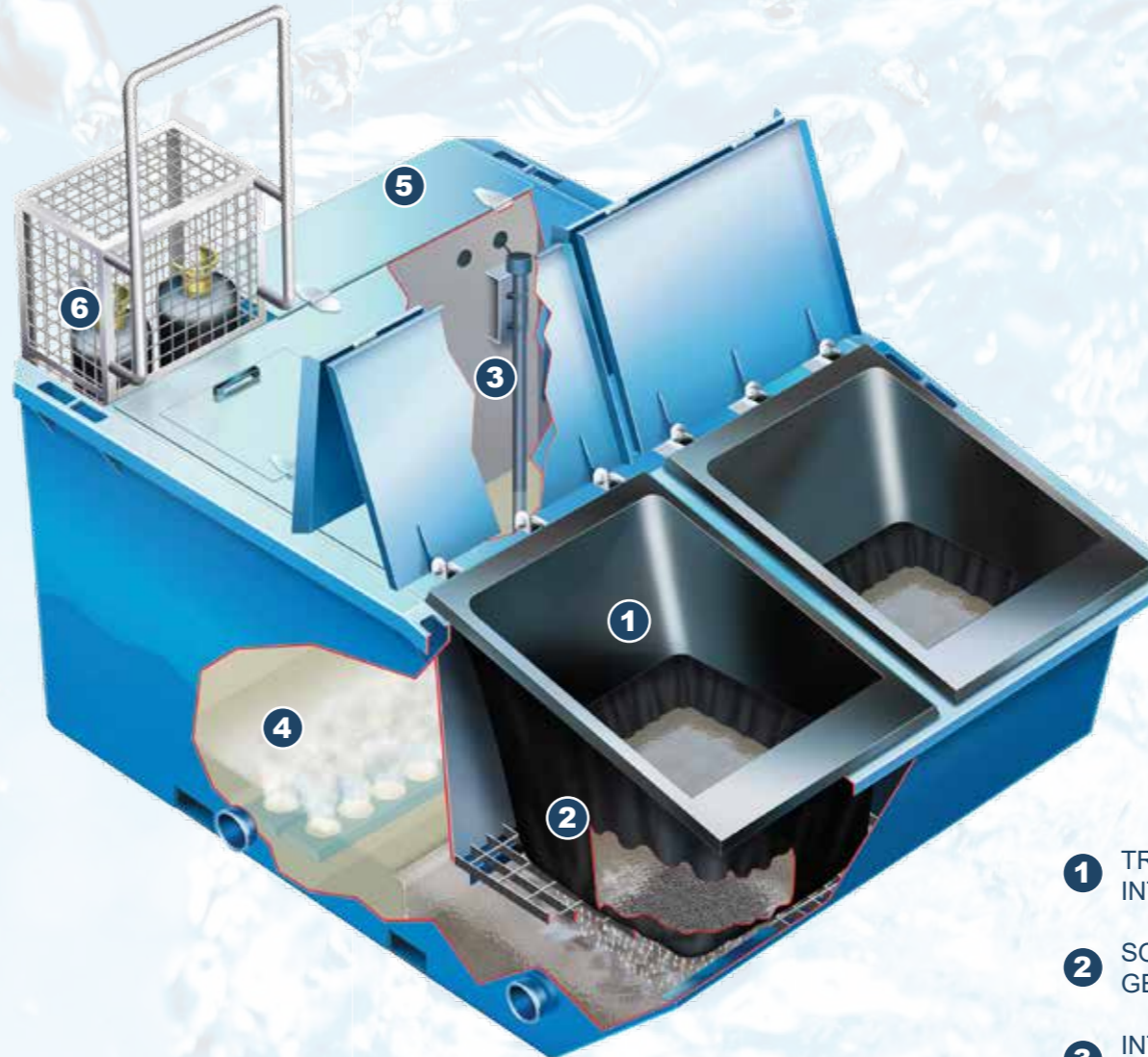

KEY ADVANTAGES

- + Self contained system - Ready to Run
- + Runs off built in 12V battery for 2000 hours
- + Readily transportable, fast and simple to deploy, easy to operate, low maintenance
- + Optional data logger (see ancillaries list)

TYPICAL APPLICATIONS

- + Remote sites without power or water
- + Medium to large concrete pours
- + Sites needing a compact wash out solution
- + Wind farms, industrial buildings, civils infrastructure projects

- 1** TRUCKS WASH OUT INTO HOPPERS
- 2** SOLIDS RETAINED IN GEOTEXTILE BAGS
- 3** INTEGRATED pH PROBE
- 4** MICROFINE CO₂ DIFFUSERS
- 5** RUNS OFF BUILT IN 12V BATTERY
- 6** DUTY AND STANDBY CO₂ CYLINDERS

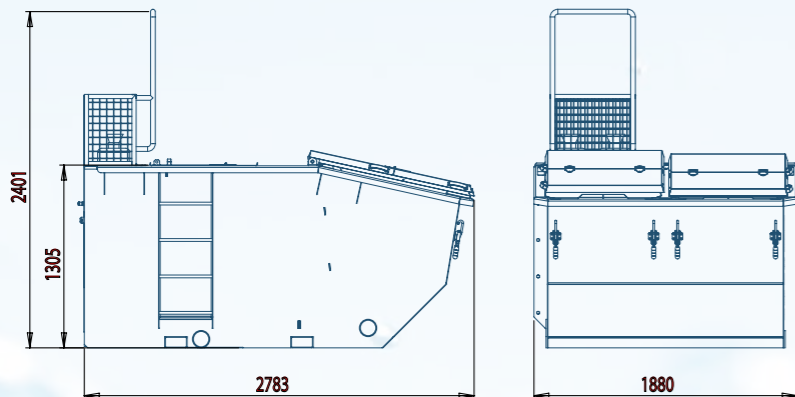

RCW Data Sheet	
Length:	2.8 m
Width:	1.9 m
Height:	2.5 m
Empty Weight:	1,200 kg
Capacity:	30 Trucks/Day
Outlet Size:	2" M Bauer
Power Req:	Inc. Battery



For Hire, Sales & Technical Support call Siltbuster® on 01600 772256

Siltbuster pH₂

CO₂ pH Adjustment Skid



The Unit

Siltbuster's compact pH₂ unit is designed to provide a cost effective method of treating high pH concrete washwater, enabling both small and large construction sites to remain compliant.

The unit has been developed for use with either plastic lined builders skips or in combination with our range of primary reception units, which include:

- Dewatering bags for the smallest sites
- Concrete pump wash out trays
- Concrete Aggregate Reclaimer

Did you know...

By using CO₂ the typical cost of treating high pH water is only **£0.30 per m³**.

For comparison the cost of using Citric / Fruit Acid is typically over **£2.40 per m³**.

How It Works

The pH₂ makes use of a bespoke pH controller and uses carbon dioxide vapour to neutralise the alkaline concrete wash water.

- The coarse aggregate is allowed to settle within the primary washdown via a submersible pump (supplied with pH₂) vessel, whilst the supernatant, alkaline water is transferred to a secondary vessel
- Within the secondary vessel the pH of the water is monitored by our automatic pH controller and neutralised via microfine CO₂ bubbles
- Once neutralised the treated water can be discharged either to a surface water course or Foul Sewer

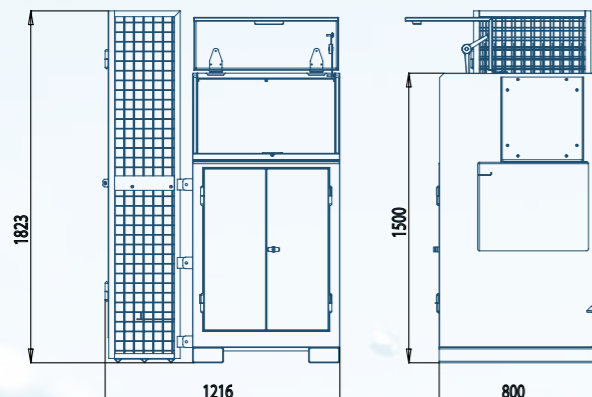

pH ₂ Data Sheet	
Length:	1.2 m
Width:	1.0 m
Height:	1.8 m (inc Cage)
Empty Weight:	500 Kg
Capacity:	Feed Dependant
Power Req:	110V 16A
** Can Be Shipped on a Pallet **	



KEY ADVANTAGES

- + Digital controller eliminates the risk of under / over adjusting the pH
- + Readily transportable, fast & simple to setup
- + Easy to operate & can be shipped via pallet
- + Optional data logger to record discharge compliance (see ancillaries list)

TYPICAL APPLICATIONS

- + Sites requiring washout facilities for a range of plant eg. Concrete Pumps, Crane Skip etc.
- + Can be used with existing wash out skips / catch pits on site
- + Sites with limited space requiring a solution with a minimal footprint

- 1 TRANSFER PUMP INCLUDED
- 2 pH PROBE & DIGITAL CONTROLLER
- 3 INTEGRATED GAS BOTTLE AND CAGE
- 4 MICROFINE CO₂ DIFFUSER
- 5 BUILT IN BATTERY FOR OVERNIGHT USE
- 6 TREATED WATER IS pH NEUTRAL



For Hire, Sales & Technical Support call Siltbuster® on 01600 772256

Big pHil

Column / Crane Skip Washout Stands



The Unit

Big pHil is a column skip washout system incorporating solids removal, pH adjustment and a "grey water" storage tank, enabling reuse of the treated water for further wash downs.

The stand supports both small and large concrete crane skips without the need for a crane. The built in walkway allows the operator to safely wash out any remaining cement and aggregate.

Big pHil provides a convenient site washout point and contains the washwater as well as separating the waste concrete solids & aggregates. The unit uses an automatic carbon dioxide pH adjustment system to neutralise the cement laden water so it can be safely recycled for washing.

How it Works

- The column skip is lowered onto the stand where it is supported at an angle enabling easy access for washing down into the washdown tray. Coarse solids are retained within the washdown tray
- Wash water weirs over into a pump chamber, where waters are pumped over a floc block and into a solids retention bag, allowing finer particles to settle
- Water weirs over into the "grey water" tank and is recirculated through the integrated pH adjustment system to neutralise the pH
- An integrated pressure washer allows the "grey water" to be reused for further washdowns

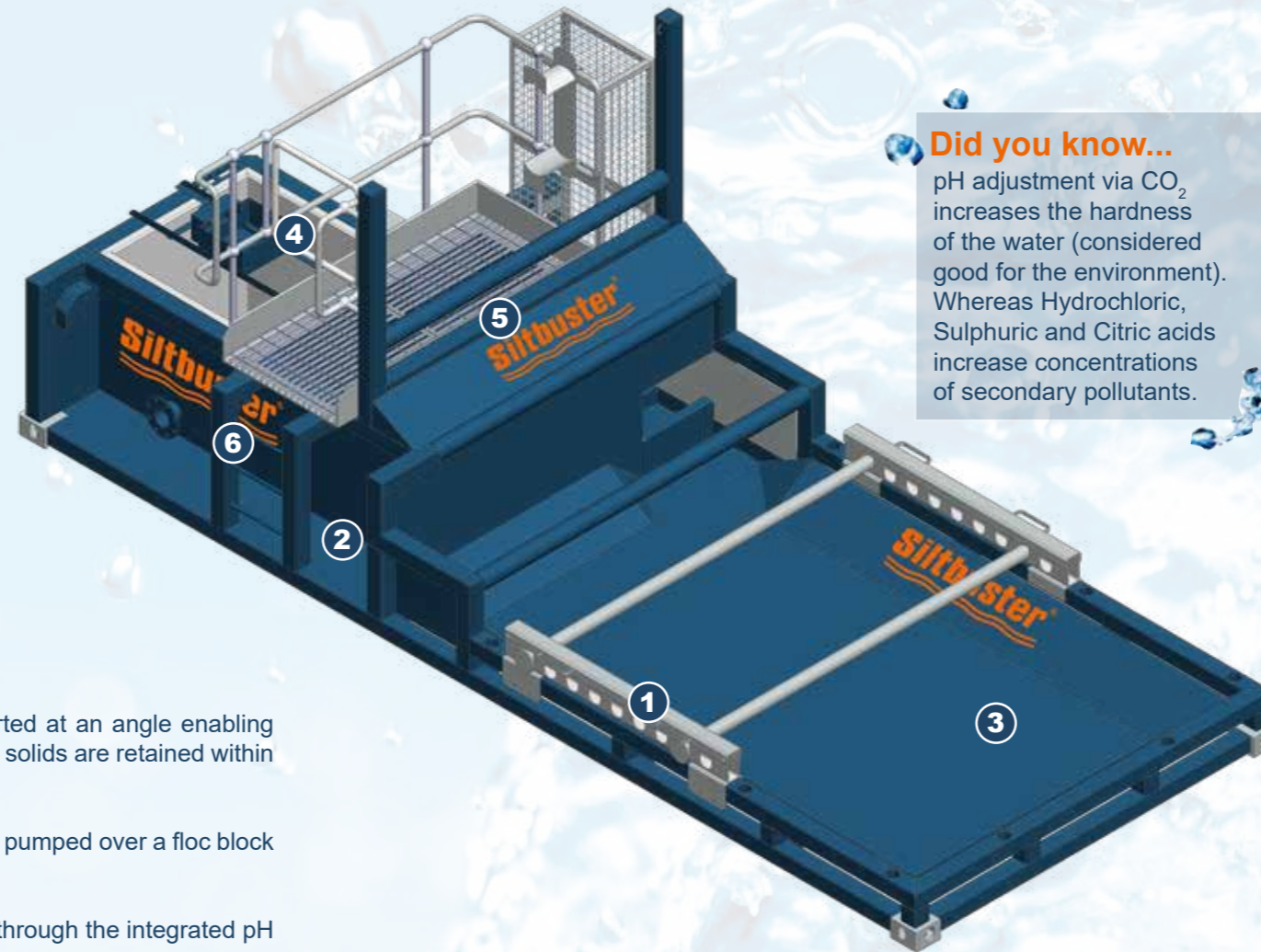

Did you know...

pH adjustment via CO₂ increases the hardness of the water (considered good for the environment). Whereas Hydrochloric, Sulphuric and Citric acids increase concentrations of secondary pollutants.

KEY ADVANTAGES

- + Adjustable rack to suit a variety of column skips
- + Integrated grey water holding tank
- + Reception hopper can be emptied by either excavator or tipping the skid

TYPICAL APPLICATIONS

- + High volume concrete pours
- + High rise / inner city concrete pours
- + Use with concrete column skips
- + Provides a safe means of washing out column skips without needing a crane

- 1** ADJUSTABLE RACK TO SUIT SKIP SIZE
- 2** BUILT IN ACCESS PLATFORM & LADDER
- 3** COARSE SOLIDS HELD IN RECEPTION HOPPER
- 4** FLOC BLOCKS & FINES SETTLEMENT
- 5** INTEGRATED GREY WATER STORAGE
- 6** pH ADJUSTMENT SYSTEM
- 7** INTEGRATED PRESSURE WASHER

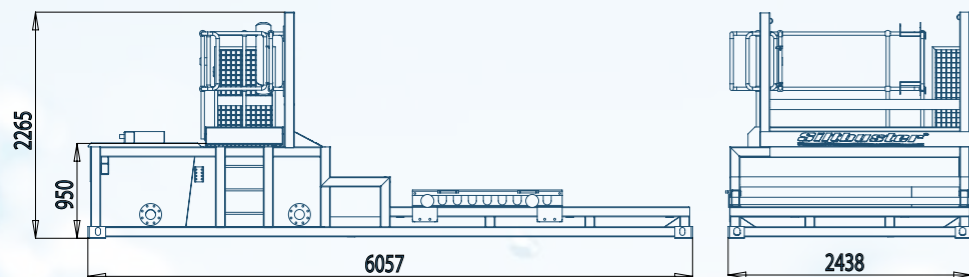

Big pHil Data Sheet	
Length:	6.1 m
Width:	2.6 m
Height:	2.6 m
Empty Weight:	2,100 Kg
Water Capacity:	1250 L
Solids Capacity:	4 m ³
Power Req:	110V 32A

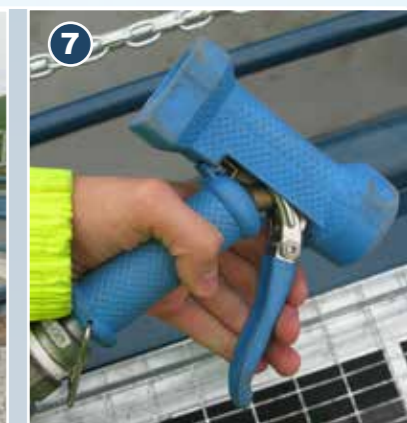

For Hire, Sales & Technical Support call Siltbuster® on 01600 772256

HD Unit

Hydrodemolition Blast Water Treatment

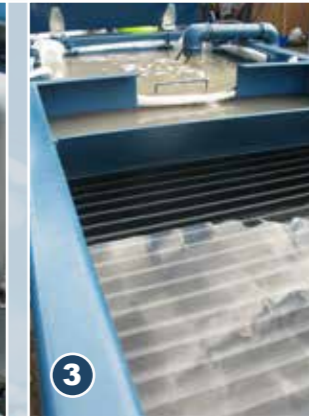
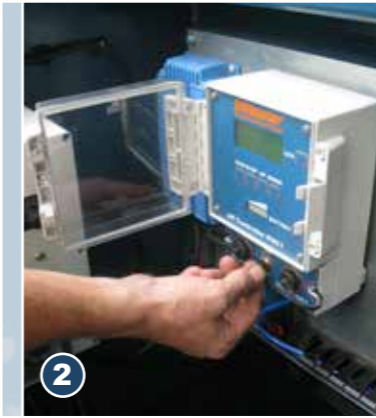

The Unit

The Siltbuster HD unit is a compact, easily transported and effective means of treating high pH, sediment laden water from hydrodemolition projects.

The HD Unit can operate continuously at a flow rate of up to 5m³/hr and is powered via its internal battery or a 110V power supply.

The unit can be operated either at ground level or directly from a works van, enabling it to be easily moved around site or removed at the completion of the shift.

It is the ideal solution for use in remote locations such as motorways, removing the requirement for a generator and additional lifting equipment.

Did you know...

Not only freshly poured concrete causes an elevated pH. Broken or cut concrete has the same effect, exposing fresh lime which reacts with water forming a strong alkaline product.

How it Works

- Hydrodemolition blast waters are pumped in to the inlet of the HD unit where rapidly settling solids are captured in a removable solids retention bag
- As necessary, Carbon Dioxide (CO₂) is automatically introduced via ceramic diffusers creating a stream of microfine bubbles to reduce the pH
- The neutralised water weirs over into an integrated lamella clarifier whereby the fine suspended solids are settled out of suspension
- Solids free, pH neutral water is then discharged out of the unit via an outlet weir
- If required, a flocculant can be introduced in to the feed waters to improve the settling velocities of the incoming solids



KEY ADVANTAGES

- + Compact and light enough to run from the back of a van
- + Removes the need to tanker waste water away from site
- + Small footprint allows use on highway hard shoulders with minimal interference

TYPICAL APPLICATIONS

- + Hydrodemolition blast water treatment from concrete repair jobs
- + Concrete cutting and high pressure water jetting treatment
- + Integrated pH correction and suspended solids removal for low flow rate jobs

- 1** BLASTWATER ENTERS SOLIDS RETENTION BAG
- 2** MICROFINE CO₂ DIFFUSER
- 3** INTEGRATED LAMELLA CLARIFIER
- 4** TREATED WATER WEIRS OUT THE UNIT
- 5** FLOCCULANT INTRODUCED (IF REQUIRED)
- 6** RUNS OFF BUILT IN 12V BATTERY

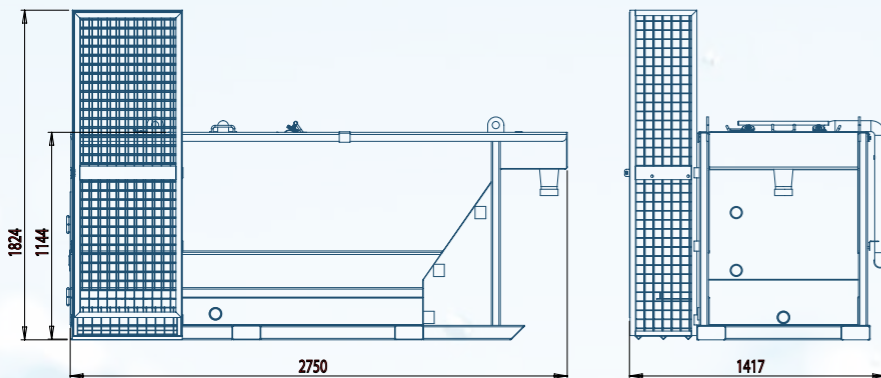

HD Unit Data Sheet	
Length:	2.8 m
Width:	1.3 m
Height:	1.8 m
Empty Weight:	650 Kg
Capacity:	1-5 m ³ /h
Inlet Size:	2" F Bauer
Outlet Size:	3" M Bauer
Power Req:	Inc. Battery

For Hire, Sales & Technical Support call Siltbuster® on 01600 772256



EcoClear

Robotic Hydrodemolition Water Treatment

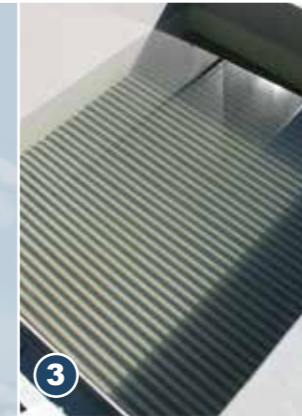
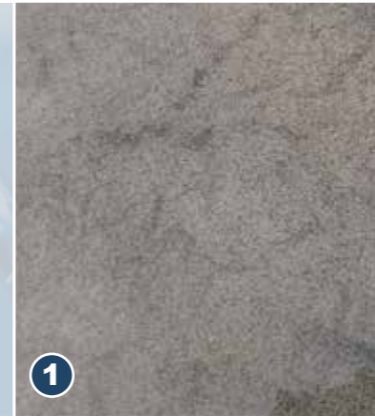

The Unit

The EcoClear has been designed and developed in partnership with Robotic Hydrodemolition market leaders Aquajet to treat high pH solids laden blast water.

The system is capable of neutralising elevated alkaline pH levels as well as removing concrete fines from suspension that cause the discoloured appearance of the water.

The EcoClear can operate continuously at a flow rate of up to 20m³/hr and is designed to treat the waste to a high quality standard suitable for safe discharge back into the environment.

Alternatively, the unit can be deployed as a complete water treatment solution for slow settling solids applications.

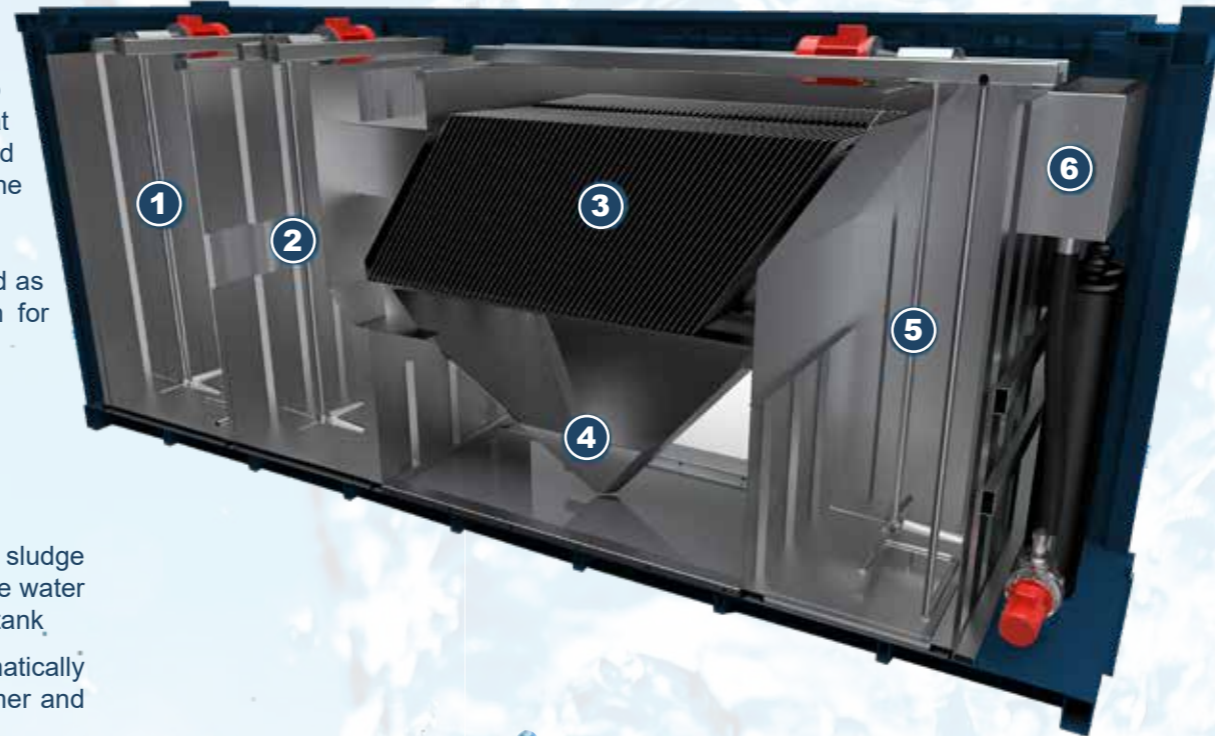

KEY ADVANTAGES

- + Automated pH Adjustment
- + Flow proportional chemical dosing
- + Water quality monitoring and logging
- + Insulated chemical storage

TYPICAL APPLICATIONS

- + Robotic hydrodemolition on applications such as:
 - Concrete pillars, piles and columns
 - Road overlays
 - Bridges/Buildings/Structures
 - Slow settling solids

How it Works

- Hydrodemolition blast waters are pumped into the EcoClear where a digital pH probe and controller measures the pH value in real time
- In the first chamber carbon dioxide is automatically introduced into the water to reduce the pH to 10.5, promoting the precipitation of solids.
- A coagulant and flocculant's are introduced on a flow proportional basis to aggregate the fine sized cementitious particulates in to rapidly settling clumps
- The water passes into a lamella clarifier allowing the chemically conditioned solids to settle out of suspension.
- The solids are held within the sludge storage hopper and the solids-free water weirs over in to the final reaction tank
- The captured solids are automatically be drawn off using the built in timer and sludge pump
- Secondary pH adjustment occurs in the final reaction tank, reducing the pH from 10.5 to 7(neutral)
- Online water quality monitoring equipment is used to measure the pH and turbidity/clarity of the treated water

Did you know...

The EcoClear has been specifically developed for use with Aquajet's Aqua Cutter range of Hydrodemolition robots, providing a packaged water treatment solution.

- 1** INLET CHAMBER AND FLOCCULATION
- 2** CO₂ pH ADJUSTMENT AND CONTROLLER
- 3** INTEGRATED LAMELLA CLARIFIER
- 4** SLUDGE STORAGE HOPPER
- 5** SECONDARY pH ADJUSTMENT
- 6** TREATED WATER MONITORING TANK

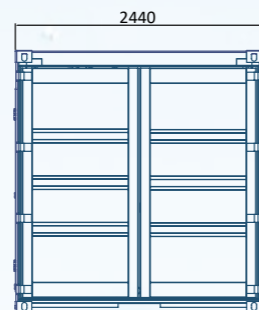
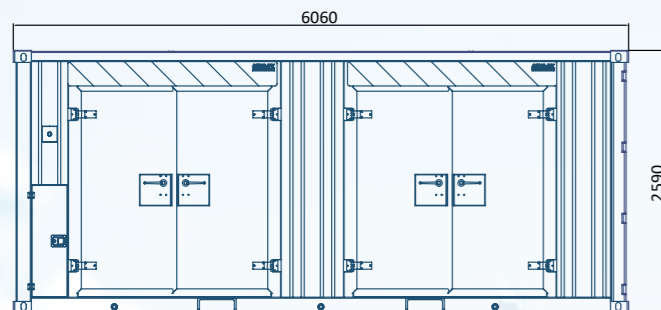

EcoClear Unit Data Sheet	
Length:	6.1 m
Width:	2.4 m
Height:	2.6 m
Empty Weight:	6000 kg
Capacity:	20 m ³ /h
Power Req:	KVA or Volts + Amp



Concrete Reclaimer

Sand and Aggregate Recovery

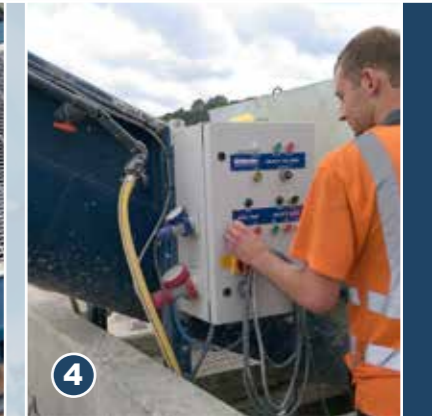

The Unit

The Siltbuster Concrete Reclaimer has been designed to accept residual concrete from mixer trucks, batching plants and other concreting equipment. The unit is configured to separate, clean and stockpile the aggregate fraction.

When used in conjunction with a Siltbuster pHD and simple settlement tank the cement fines can be settled out from the washwater under gravity and the high pH water adjusted safely using carbon dioxide for disposal.

The Siltbuster Concrete Reclaimer:

- Is capable of processing 0 to 10 T/hr with a maximum particle size of 100mm depending upon site specific conditions
- Washes and cleans sand and aggregate
- Is ideally suited to applications where costs have previously prevented aggregate reclamation

How it Works

- Mixer truck reverses upto the reclaimer
- Excess concrete and wash down water is discharged into the reception chamber
- Sand and aggregate settles through water
- Water and suspended cement fines weir out of the discharge from the reclaimer
- An optional screen can be used to recover reinforcing fibres
- Aggregate is carried up the dewatering auger
- Spray bars provide a final rinse before discharge

Did you know...

Over 4.5m³ of sand and stone per week is recovered from our Concrete Reclaimer on the site of one of our clients, enabling them to reuse the material, which previously went to landfill!

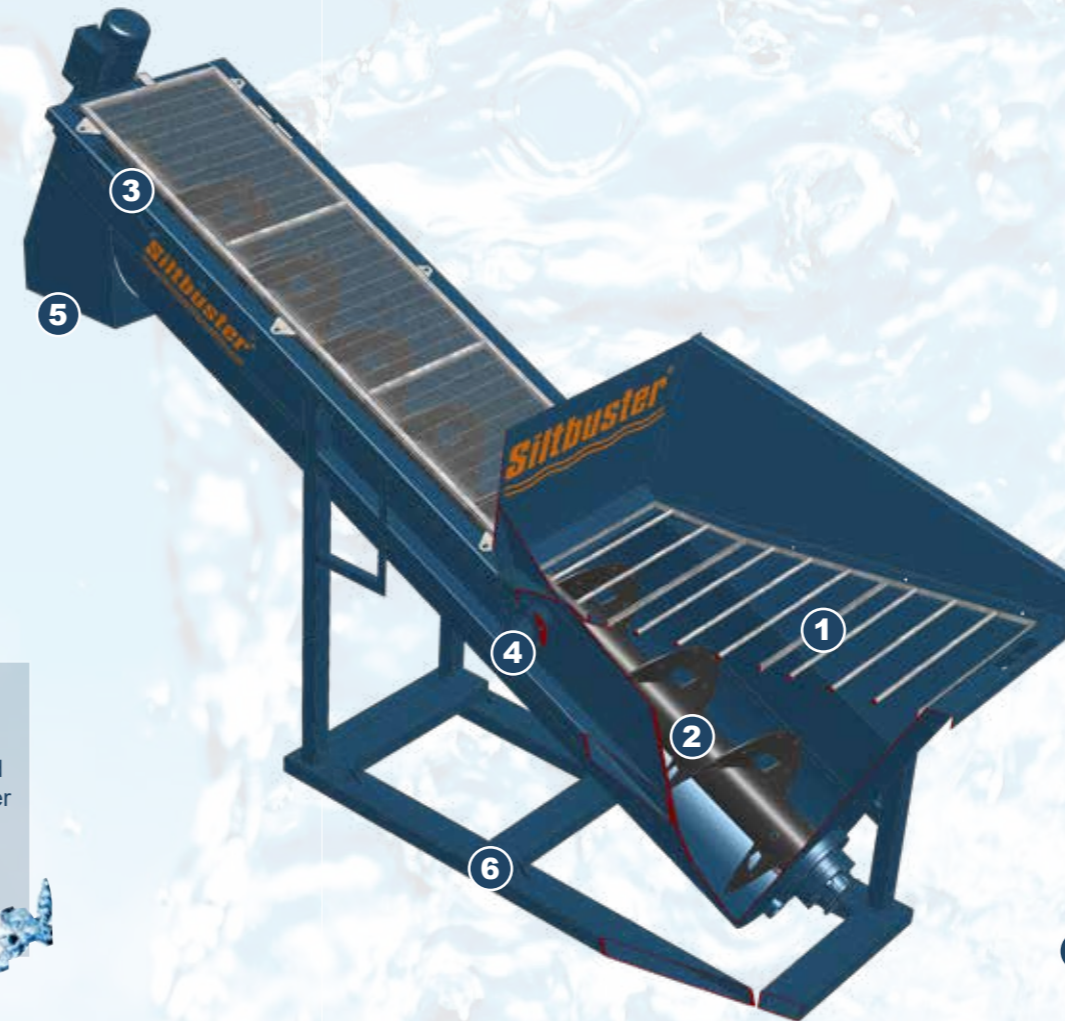

KEY ADVANTAGES

- + Reduces landfill disposal
- + Enables reuse of sand and aggregate
- + Compact footprint allows use on site
- + Skid mounted and easily portable

TYPICAL APPLICATIONS

- + Mixer truck drum washouts
- + Batching Plants
- + Large Civil Engineering Projects
- + Processing part loads

- 1 RECEPTION CHAMBER
- 2 SAND & AGGREGATE DEWATERING AUGER
- 3 EXTRA RINSE SPRAY BARS
- 4 OVERFLOW PORT & CONTROL PANEL
- 5 AGGREGATE DISCHARGE POINT
- 6 SKID WITH FORKLIFT SLOTS

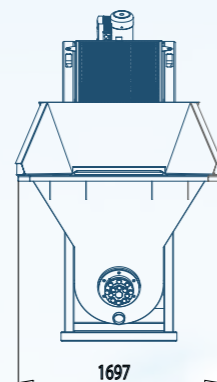
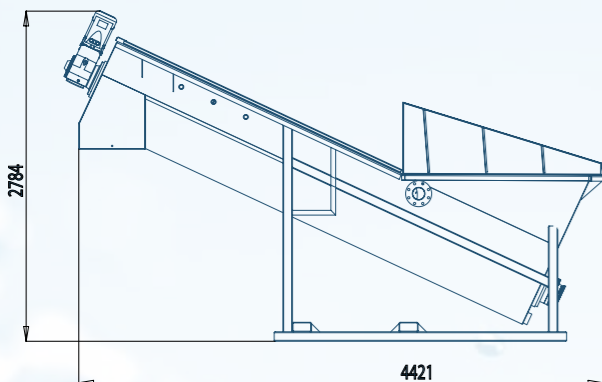

Concrete Reclaimer Data Sheet	
Length:	4.6 m
Width:	1.7 m
Height:	2.7 m
Empty Weight:	1500 Kg
Capacity:	8 T/h
Power Req:	415v 16 Amp 3 phase N + E



DS4

pH Adjustment Skid



The Unit

The Siltbuster DS4 is a single stage pH adjustment system and can be configured to adjust the pH of either alkaline or acidic waters at flow rates of up to 20 m³/hr.

The unit can operate using either strong Mineral Acid, Carbon Dioxide or Sodium Hydroxide depending upon whether the unit is being used to increase or decrease the pH level.

For treatment of waters containing suspended solids, the Siltbuster DS4 can be operated in conjunction with a Siltbuster FB50 Settlement Unit, which when combined enables continuous pH adjustment and solids removal.

Did you know...

Using CO₂ as the neutralising agent (as opposed to Mineral or Fruit Acids) does not increase the Chloride, Sulphate or COD (Chemical Oxygen Demand) of the water.

How it Works

- An integrated probe and pH controller monitors the pH levels of the water, automatically controlling the CO₂ dose rates
- Depending upon configuration, either CO₂ vapour is bubbled through the water to reduce the pH or Sodium Hydroxide is added to increase the pH level
- The integrated mixer and impeller ensures any chemicals introduced are thoroughly mixed and any solids present remain in suspension
- A magnetic flow meter on the inlet of the DS4 detects the flow rate of water entering the unit (when used as a mix tank)

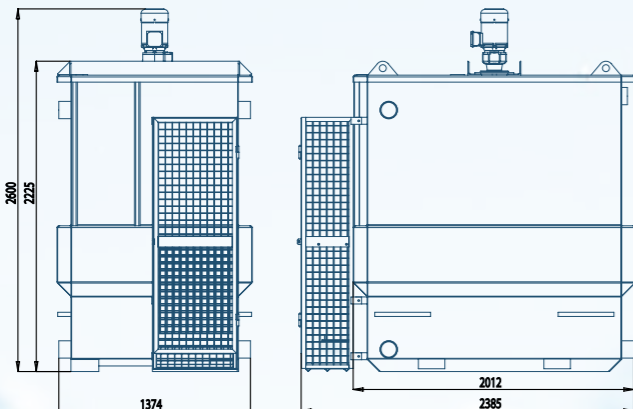

DS4 Data Sheet	
Length:	2.4 m
Width:	1.4 m
Height:	2.4 m
Empty Weight:	1,200 Kg
Capacity:	1-20 m ³ /hr
Inlet Size:	4" F Bauer
Outlet Size:	4" M Bauer
Power Req:	110V or 415V



KEY ADVANTAGES

- + Can be used with either CO₂, Acids or Alkalines for pH adjustment
- + Integrated mixers ensure thorough mixing of chemicals and reagents
- + Modular design allows easy use with other Siltbuster plant to form a treatment solution

TYPICAL APPLICATIONS

- + Used for applications requiring pH adjustment
- + Continuous flows requiring pH adjustment
- + Lime stabilisation works, concrete crushing, grouting, in situ piling & demolition works

- 1 INTEGRATED CO₂ SPARGER
- 2 MIXERS KEEP SOLIDS SUSPENDED
- 3 INTEGRATED GAS BOTTLE STORAGE
- 4 pH CONTROLLER AND PROBE
- 5 OPTIONAL INLINE FLOW METER



For Hire, Sales & Technical Support call Siltbuster® on 01600 772256

PMPU

pH Adjustment & suspended solids removal



The Unit

Siltbuster's PMPU10 and PMPU20 units offer integrated pH adjustment and fine solids separation for flow rates of up to 30 m³/hr.

Ideal for treating high pH, cementitious wash water from concrete batching plants, tunnelling works and precast concrete factories. However, the system is equally as effective within a construction environment.

Utilising an integrated 3 stage treatment process, the unit maximises pH adjustment, solids precipitation and removal within the footprint of a single skid.

Automatic Carbon Dioxide dosing ensures optimum pH levels are maintained.

How it Works

The Siltbuster PMPU Unit provides three stages of treatment within a single integrated unit. These stages are:

- Stage 1: Initial pH adjustment to achieve a pH of circa 10.5 to maximise the precipitation of solids
- Stage 2: Recovery of suspended solids within a clarification stage. The settled solids collect within a hopper and can be removed by opening the gate valve and can be pumped into a skip or sludge storage tank for dewatering or off-site disposal
- Stage 3: Final stage pH adjustment to achieve a user set pH. The clean, pH adjusted, sediment free water will then be discharged from the outlet weir of the unit

Did you know...

Typical discharge consents for controlled waters (surface water/groundwater) require a pH of between 6 and 9. Whereas discharging to sewer a pH between 5 and 10 is typically permitted.



KEY ADVANTAGES

- + Digital pH controller means minimal labour required
- + Readily transportable, fast and simple to deploy, easy to operate
- + Optional data logger to record discharge compliance

TYPICAL APPLICATIONS

- + Avoids the health and safety risks associated with handling acid
- + Digital controller eliminates the risk of under / over adjusting the pH
- + Does not increase the Chloride, Sulphate or COD (Chemical Oxygen Demand)

- 1** INTEGRATED CO₂ SPARGER
- 2** MIXERS KEEP SOLIDS SUSPENDED
- 3** INTEGRATED LAMELLA CLARIFIER
- 4** SECOND STAGE pH ADJUSTMENT
- 5** SLUDGE STORAGE HOPPER & PUMP
- 6** TYPICALLY USED WITH BULK CO₂

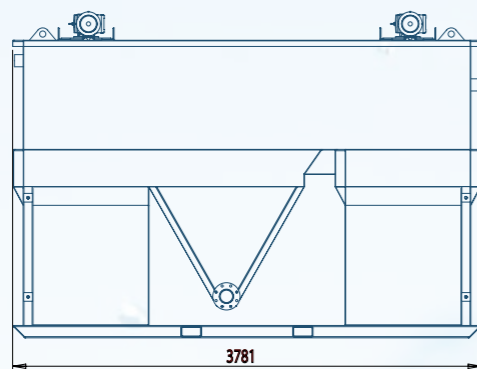
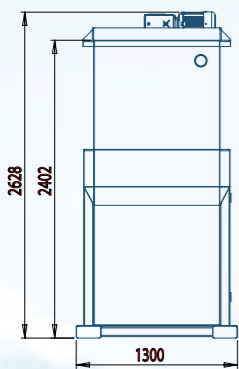

PMPU Data Sheet		
	PMPU10	PMPU20
Length:	3.2 m	3.8 m
Width:	1 m	1.3 m
Height:	2.2 m	2.7 m
Empty Weight:	1,200 Kg	2,500 Kg
Capacity:	0-15 m ³ /hr	0-30 m ³ /hr
Inlet Size:	4" F Bauer	
Outlet Size:	4" M Bauer	
Power Req.	415V 32A	



For Hire, Sales & Technical Support call Siltbuster® on 01600 772256

Concrete Wash Water Case Studies

Network Rail Bridge Improvement Works

BAM Nuttall

Bam Nuttall were contracted by Network Rail to undertake improvement works to a Rail Bridge in Pullbrough.

As part of the project up to 30 concrete trucks delivered to the site per day. To cater for the wash water generated from these trucks, BAM utilised one of their own Siltbuster RCW units to provide an on-site concrete washout solution.

In addition to their own Siltbuster RCW, BAM hired an additional Siltbuster pHD unit, which was used in conjunction with the RCW unit on another part of the site.



Apartment Block, Manchester City Centre

Renaker Build

During the construction of new apartments in the centre of Manchester, large volumes of concrete were being poured as part of the works.



With trucks moving back and forth across site, large quantities of wash water was used for the cleaning of the wagon's chutes which required treatment prior to disposal to the foul sewage network.

A Siltbuster RCW unit was installed to handle 20 truck wash downs per day. The alkaline pH level was automatically neutralised and the associated aggregates and particulates were removed from suspension.

Initially hiring a Siltbuster RCW unit for the project, Renaker have since purchased two liveried units for their own internal plant fleet.

Wind Turbine Bases

Lynch Plant Hire

The construction of a wind turbine base in Norfolk required a large quantity of rebar and concrete.

This particular phase of works resulted in concrete mixer trucks continuously pouring throughout the day, all of which required cleaning without the wash water damaging the surrounding environment.

Siltbuster installed a pHD unit, delivered to site next day on a single pallet, minimising plant transport costs.

The unit was setup with two skips, one for washout and one for pH adjustment. The addition of a Siltbuster pHD allowed Lynch Plant to instantly upgrade the onsite washout facilities.



Concrete Wash Water Case Studies

Falmouth New Dry Docks Installation

Raymond Brown Construction

Expansion works in Falmouth required the creation of a new sea wall as well as two new wet docks, three construction halls and a four-storey office complex. All requiring large quantities of concrete, leading to the need for a solution to deal with the wash water.

A Siltbuster pHD was quickly deployed to site via a pallet, and operated in conjunction with two standard builders skips lined with plastic. Trucks would back up and clean their chutes into one, while the water was over pumped and treated in skip two.

This low cost solution handled multiple washdown events on a daily basis and ensured the pH of the water discharged off site was within the range of 6-9 set out by the Environment Agency.



Bath Quays Commercial and Office Development

Thames Valley Construction

A concrete washout solution was needed for a phase of the development works. The site adjacent to the River Avon was described as busy and space was extremely limited.

The site team required a compact self-contained treatment system that would treat and recycle the concrete washwater so that it could be reused for further washdown events. The recycling of the water was particularly important as it limited the volume of water that would be discharged or tankered off site.

To meet the site requirements Siltbuster mobilised the MCW unit and carried out an onsite training session for a number of site operatives.



Concrete Batching - Aggregate Recovery

Easycrete

Easycrete provide ready mixed concrete to construction sites across much of the South East of England. At their site in Surrey they required a solution to help them to recover the aggregate and sand from left over concrete.

Siltbuster provided Easycrete with its Concrete Reclaimer which separates the cement particles from aggregate which usually forms up to 80% of concrete.

Wet concrete is tipped into the flooded reception hopper of the reclaimer. From here the aggregate moves up the trough via an auger and is washed with fresh water jets ensuring a clean product.

The reclaimed aggregate from the Siltbuster unit has enabled Easycrete to recover 4.5m³ of sand and aggregate per week which would have otherwise been disposed to landfill.



pH Adjustment Case Studies

Robotic Hydrodemolition Works Aquajet AB, Sweden

In the Swedish town of Malmö, the Hydrodemolition specialist, NVB, were performing a large renovation of a parking garage. The garage is located in an urban environment with highly regulated noise, pH and turbidity levels.

The job required the use of robotic Hydrodemolition technology, whilst ensuring the water would be safely discharged back into to the city's run-off water system with TSS (Total Suspended Solids) below 20 mg/L – a strict requirement from the municipal authorities in Malmö.

With the EcoClear, NVB were able to achieve a steady level of 15 mg/L, and could automatically neutralize the water to pH 7.



Precast Concrete Manufacturer Bison Manufacturing



Bison Manufacturing produce precast concrete products such as flooring and structural framing components.

At their factory in Swadlincote, Bison required a water treatment plant to deal with the pH 13, solid laden water generated as a result of cleaning the precast moulds.

Siltbuster installed its PMPU20 unit on site to remove solids from the water and treat the high pH levels. The Siltbuster unit has enabled Bison to achieve their target under the "British Precast Sustainability Charter" and continue to grow sustainability.

Lake Retaining Wall Grouting Colwell Groundworks

A three acre lake containing carp, perch and roach totalling £1 million had a leaking retaining wall which needed to be repaired. Water which came into contact with the recently poured concrete quickly took on an alkaline pH value, which, if released back into the lake would likely damage and kill life within the ecosystem.

As part of the National Heritage Project, Siltbuster were tasked with identifying a solution to ensure the risk of harming the wildlife by polluting the lake was minimised.

With limited space being a key driving factor, and best practice not wanting to be compromised, the Siltbuster HD unit was selected. Small enough to be positioned in the tightest location, the battery operated pH adjustment unit automatically neutralised the alkaline waters present and removed any solids from suspension.



pH Adjustment Case Studies

Bridge Deck Repairs Requiring Hydrodemolition Sabre Jetting

A large bridge deck needed its concrete surface to be repaired, Sabre Jetting were tasked with removing the damaged concrete by the use of hydrodemolition.

With works taking place above a surface water course, the alkaline blast waters needed to be captured and treated before being discharged into the surrounding environment.

The high pH water was captured and fed into the compact HD unit to remove the suspended solids and neutralise the water back to pH 7 before being safely discharged it in to the watercourse.

The compact nature of the Siltbuster HD unit ensured work at the side of a motorway could continue with minimal space requirements.



pH Adjustment of Car Park Storm Water Bentley Motors

Bentley Motors had recently installed a new 5.5 hectare carpark to allow for future expansion with an integral concrete drainage network.

After two members of Bentley Motors environmental team had attended one of Siltbuster's CPD courses they further understood the cause of a white precipitate that was occurring in their attenuation ponds.

The elevated pH from the new car park, resulted in Calcium Carbonate being precipitated when the pH of the runoff decreased in the ponds.

To resolve this issue, Siltbuster installed a PMPU20 unit to reduce the pH in a controlled manner, precipitating and removing all of the dissolved material prior to being discharged.



Road Bridge Repair Works Forkers Ltd

During road bridge repair work, Forkers were required to replace existing pipe work without affecting the integrity of the bridge. To achieve this Forkers used ultra high pressure water to cut away the concrete (hydrodemolition).

As a result of the hydrodemolition work, Forkers required a solution to deal with the high pH blast water.

Siltbuster supplied a two stage treatment system consisting of a DS4 (for pH Adjustment) and an FB50 settlement unit (for suspended solids removal) to effectively treat the high pH blast water.

Once treated the water was then released to a nearby surface watercourse.



Siltbuster[®]



Hire, Sales & Technical Support

Tel: +44(0)1600 772256

Visit: www.siltbuster.com

Email: enquire@siltbuster.com



THE QUEEN'S AWARDS
FOR ENTERPRISE:
INNOVATION
2017



Siltbuster Ltd, Williams Building, Kingswood Gate, Monmouth, Monmouthshire, NP25 4EE